

Symbol

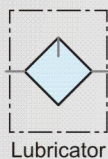

Features

- * Lubricator oil can be replenished without stopping air supply.
- * Oil spray in mist ensures good lubrication for machines.

How to order

UL	—	02	N	B	A
Lubricator		Port size	Thread	Mounting	Bowl
		02 1/4"	Blank PS	Blank W/O bracket	Blank Standard bowl
		03 3/8"	N NPT	B W/I bracket	A Anti-acid & alkali bowl
		04 1/2"			AL Aluminum bowl (1/4"~1/2")
		06 3/4"			
		08 1"			

Specifications

Model	UL-02	UL-03	UL-04	UL-06	UL-08
Port size	1/4"	3/8"	1/2"	3/4"	1"
Fluid	Compressed air				
Body material	Aluminum die-cast				
Bowl material	Polycarbonate (Standard), Anti-acid & alkali bowl (Option), Aluminum bowl (Option)				
Operating pressure range	0.5 ~ 10 kgf/cm ²				
Max. operating pressure (Standard bowl)	15 kgf/cm ²				
Max. flow rate l/min (6kgf/cm ²)	2490	2525	4310	8400	9000
Ambient temperature	-10°C ~ 60°C				
Lubricator oil (Recommended)	ISO-VG32				
Lubricator bowl capacity	125cc			235cc	
Net weight	500g (W/I Aluminum bowl 800g)			1095g	

Flow chart

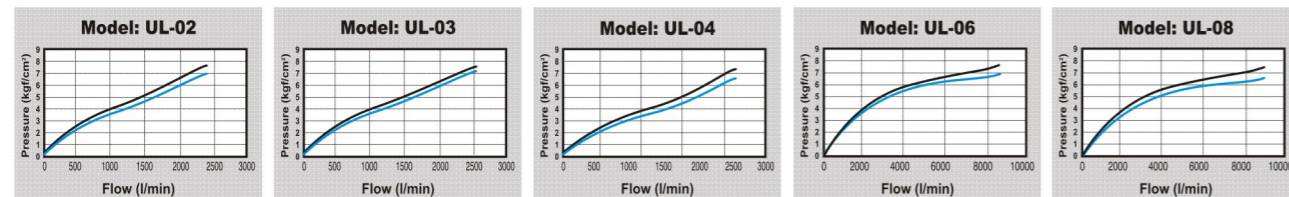

Note: X axis: Flow, Y axis: Pressure, Blue line (P0) = Outlet pressure, Black line (P1) = Inlet pressure, P1-P0=Pressure range

Dimensions

UL-02, 03, 04

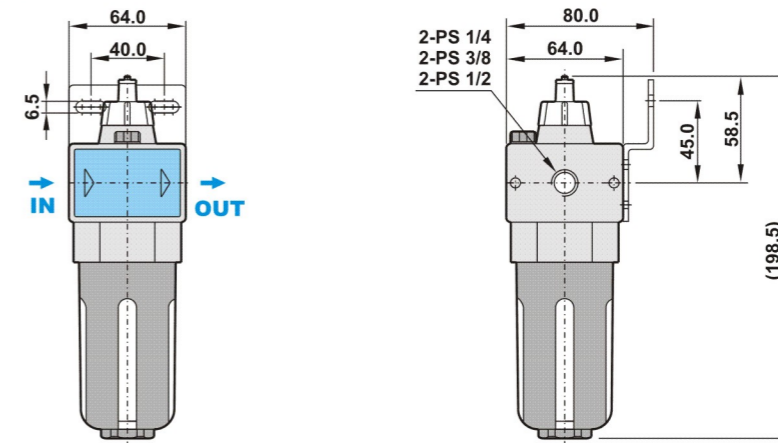

UL-02AL, 03AL, 04AL (Aluminum bowl)

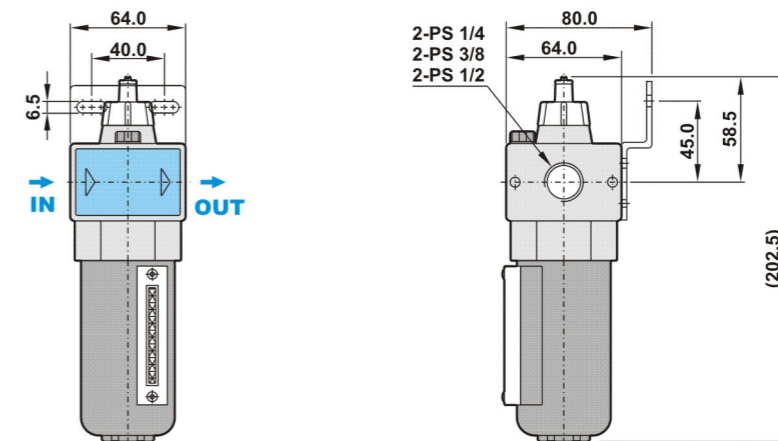

UL-06, 08

