

### Features

- \* Pilot acting for low starting pressure.
- \* Large flow rate and high working pressure.
- \* Quick response.
- \* Stainless steel body and stem provide exceptional durability.
- \* Flange type is available for JIS 10K, ANSI 150LB and PN16.
- \* Ex-proof coil T4 as optional accessory.
- \* Timer for setting on/off time as optional accessory.



### How to order

SPU225	A	N	E	F	-03	N	-S	1	LED	E
Stainless steel 2/2 way pilot acting	Series	Acting style	Diaphragm	Flange type	Port size	Thread	Solenoid	Voltage	LED	Ex-proof coil
A	Standard	Blank Normally closed N Normally open	Blank VITON B NBR E EPDM	F 10K F3 150LB F4 PN16	03 3/8" 04 1/2" 06 3/4" 08 1" 12 1-1/4" 14 1-1/2" 20 2"	Blank PS N NPT		1 110VAC 2 220VAC 9 24VDC	Blank/W/O LED	

### Specifications

Model	SPU225A-03	SPU225A-04	SPU225A-06	SPU225A-08	SPU225A-12	SPU225A-14	SPU225A-20
Port size	3/8"	1/2"	3/4"	1"	1-1/4"	1-1/2"	2"
Fluid	Compressed air (light oil, water)						
A series orifice	13mm		25mm		38mm		50mm
Sectional area	88mm <sup>2</sup>		230mm <sup>2</sup>		404mm <sup>2</sup>		883mm <sup>2</sup>
Acting	Pilot acting						
Diaphragm	VITON (Standard), NBR, EPDM (Option)						
Operating pressure range	0.5 ~ 10 kgf/cm <sup>2</sup>						
Max. operating pressure	15 kgf/cm <sup>2</sup>						
Body material	Stainless steel SUS316						
Fluid temperature	-10°C ~ 90°C						
Ambient temperature	-10°C ~ 60°C						
Installation	Horizontal						
Duty cycle	100% ED						
Coil type	DIN						
Protection class	IP65 (DIN 40 050)						
Insulation class	F						
Voltage tolerance	±10%						
Standard voltage	220VAC, 110VAC, 24VDC The other voltage is optional						
Power consumption	Normally closed AC110V:17.6VA, AC220V:18.1VA, DC: 15W ; Normally open AC: 17.8VA, DC: 15W						
Net weight	775g		1550g		2820g		4665g

### Seal material selection guide

Seal	Temperature range	Suitable fluid	Unsuitable fluid
NBR	-15°C ~ 80°C	Air, Water, Neutral gases, Mineral oil	Fuel oil, Gasoline and Hi-test gasoline, Diesel fuel
VITON	-10°C ~ 130°C	Fuel oil, Gasoline and Hi-test gasoline, Diesel fuel	Hot water, Steam, Brake oil (ATE Blue)
EPDM	-5°C ~ 160°C	Hot water, Detergent liquid	Mineral oil, Gasoline

### Dimensions

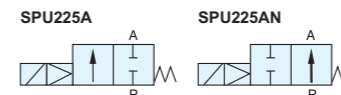

### SPU225A Standard type

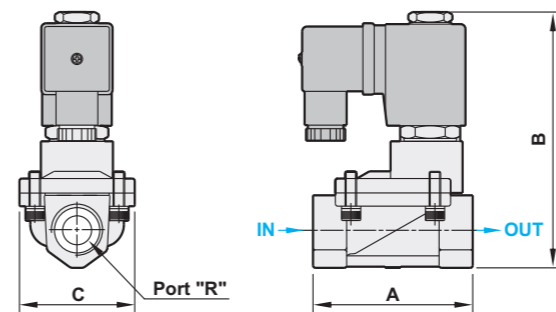

Model	SPU225A-03	SPU225A-04	SPU225A-06	SPU225A-08	SPU225A-12	SPU225A-14	SPU225A-20
R	3/8"	1/2"	3/4"	1"	1 1/4"	1 1/2"	2"
A	66.5	66.5	100.0	100.0	131.0	131.0	160.0
B	106.5	106.5	126.5	126.5	145.5	145.5	160.5
C	48.0	48.0	70.0	70.0	96.0	96.0	112.0

### SPU225A Flange type (10K)

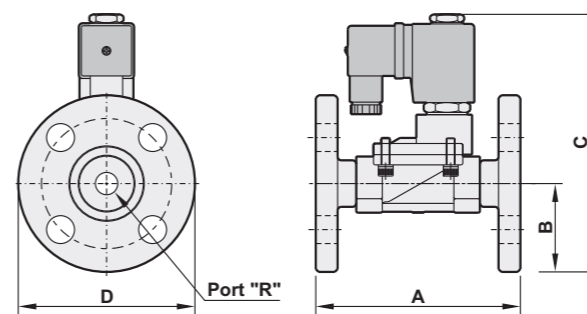

Model	SPU225AF-03	SPU225AF-04	SPU225AF-06	SPU225AF-08	SPU225AF-12	SPU225AF-14	SPU225AF-20
R	3/8"	1/2"	3/4"	1"	1 1/4"	1 1/2"	2"
A	110.0	110.0	149.0	150.0	180.0	180.0	210.0
B	45.0	47.5	50.0	62.5	67.5	70.0	77.5
C	137.0	139.5	152.5	164.0	173.0	182.5	210.0
D	90.0	95.0	100.0	125.0	135.0	140.0	155.0

### Explosion

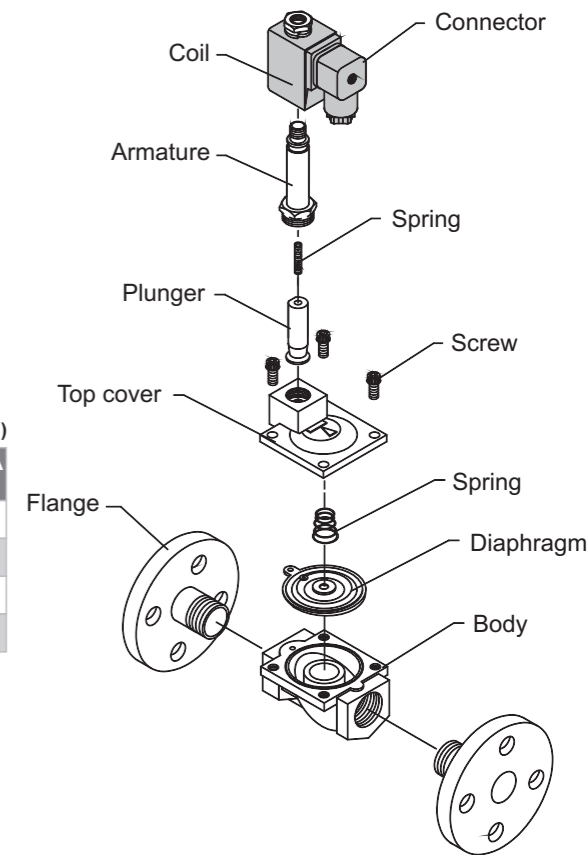

### Flow chart

